



MICROCHIP

MCP73833
Li-Ion Battery Charger
Evaluation Board
User's Guide

Note the following details of the code protection feature on Microchip devices:

- Microchip products meet the specification contained in their particular Microchip Data Sheet.
- Microchip believes that its family of products is one of the most secure families of its kind on the market today, when used in the intended manner and under normal conditions.
- There are dishonest and possibly illegal methods used to breach the code protection feature. All of these methods, to our knowledge, require using the Microchip products in a manner outside the operating specifications contained in Microchip's Data Sheets. Most likely, the person doing so is engaged in theft of intellectual property.
- Microchip is willing to work with the customer who is concerned about the integrity of their code.
- Neither Microchip nor any other semiconductor manufacturer can guarantee the security of their code. Code protection does not mean that we are guaranteeing the product as "unbreakable."

Code protection is constantly evolving. We at Microchip are committed to continuously improving the code protection features of our products. Attempts to break Microchip's code protection feature may be a violation of the Digital Millennium Copyright Act. If such acts allow unauthorized access to your software or other copyrighted work, you may have a right to sue for relief under that Act.

Information contained in this publication regarding device applications and the like is provided only for your convenience and may be superseded by updates. It is your responsibility to ensure that your application meets with your specifications. MICROCHIP MAKES NO REPRESENTATIONS OR WARRANTIES OF ANY KIND WHETHER EXPRESS OR IMPLIED, WRITTEN OR ORAL, STATUTORY OR OTHERWISE, RELATED TO THE INFORMATION, INCLUDING BUT NOT LIMITED TO ITS CONDITION, QUALITY, PERFORMANCE, MERCHANTABILITY OR FITNESS FOR PURPOSE. Microchip disclaims all liability arising from this information and its use. Use of Microchip devices in life support and/or safety applications is entirely at the buyer's risk, and the buyer agrees to defend, indemnify and hold harmless Microchip from any and all damages, claims, suits, or expenses resulting from such use. No licenses are conveyed, implicitly or otherwise, under any Microchip intellectual property rights.

Trademarks

The Microchip name and logo, the Microchip logo, Accuron, dsPIC, KEELOQ, microID, MPLAB, PIC, PICmicro, PICSTART, PRO MATE, PowerSmart, rfPIC and SmartShunt are registered trademarks of Microchip Technology Incorporated in the U.S.A. and other countries.

AmpLab, FilterLab, Migratable Memory, MXDEV, MXLAB, SEEVAL, SmartSensor and The Embedded Control Solutions Company are registered trademarks of Microchip Technology Incorporated in the U.S.A.

Analog-for-the-Digital Age, Application Maestro, CodeGuard, dsPICDEM, dsPICDEM.net, dsPICworks, ECAN, ECONOMONITOR, FanSense, FlexROM, fuzzyLAB, In-Circuit Serial Programming, ICSP, ICEPIC, Linear Active Thermistor, Mindi, MiWi, MPASM, MPLIB, MPLINK, PICKIT, PICDEM, PICDEM.net, PICLAB, PICTail, PowerCal, PowerInfo, PowerMate, PowerTool, REAL ICE, rFLAB, rfPICDEM, Select Mode, Smart Serial, SmartTel, Total Endurance, UNI/O, WiperLock and ZENA are trademarks of Microchip Technology Incorporated in the U.S.A. and other countries.

SQTP is a service mark of Microchip Technology Incorporated in the U.S.A.

All other trademarks mentioned herein are property of their respective companies.

© 2006, Microchip Technology Incorporated, Printed in the U.S.A., All Rights Reserved.

 Printed on recycled paper.

QUALITY MANAGEMENT SYSTEM
CERTIFIED BY DNV
== ISO/TS 16949:2002 ==

Microchip received ISO/TS-16949:2002 certification for its worldwide headquarters, design and wafer fabrication facilities in Chandler and Tempe, Arizona, Gresham, Oregon and Mountain View, California. The Company's quality system processes and procedures are for its PICmicro® 8-bit MCUs, KEELOQ® code hopping devices, Serial EEPROMs, microperipherals, nonvolatile memory and analog products. In addition, Microchip's quality system for the design and manufacture of development systems is ISO 9001:2000 certified.



MCP73833 LI-ION BATTERY CHARGER EVALUATION BOARD USER'S GUIDE

Table of Contents

Preface	1
Introduction.....	1
Document Layout	1
Conventions Used in this Guide	2
Recommended Reading.....	3
The Microchip Web Site	3
Customer Support	3
Document Revision History	3
Chapter 1. Product Overview	5
1.1 Introduction	5
1.2 What is the MCP73833 Li-Ion Battery Charger Evaluation Board?	6
1.3 What the MCP73833 Evaluation Kit Includes	6
Chapter 2. Installation and Operation	7
2.1 Introduction	7
2.2 Features	7
2.3 Getting Started	8
Appendix A. Schematic and Layouts	11
A.1 Introduction	11
A.2 Board Schematic	12
A.3 Board - Top Overlay	13
A.4 Board - Top Layer	14
A.5 Board - Bottom Layer	15
Appendix B. Bill Of Materials (BOM)	17
Worldwide Sales and Service	18

MCP73833 Li-Ion Battery Charger Evaluation Board User's Guide

NOTES:



MCP73833 LI-ION BATTERY CHARGER EVALUATION BOARD USER'S GUIDE

Preface

NOTICE TO CUSTOMERS

All documentation becomes dated, and this manual is no exception. Microchip tools and documentation are constantly evolving to meet customer needs, so some actual dialogs and/or tool descriptions may differ from those in this document. Please refer to our web site (www.microchip.com) to obtain the latest documentation available.

Documents are identified with a "DS" number. This number is located on the bottom of each page, in front of the page number. The numbering convention for the DS number is "DSXXXXA", where "XXXX" is the document number and "A" is the revision level of the document.

For the most up-to-date information on development tools, see the MPLAB® IDE on-line help. Select the Help menu, and then Topics to open a list of available on-line help files.

INTRODUCTION

This chapter contains general information that will be useful to know before using the MCP73833 Li-Ion Battery Charger Evaluation Board. Items discussed in this chapter include:

- Document Layout
- Conventions Used in this Guide
- Recommended Reading
- The Microchip Web Site
- Customer Support
- Document Revision History

DOCUMENT LAYOUT

This document describes how to use the MCP73833 Li-Ion Battery Charger Evaluation Board. The manual layout is as follows:

- **Chapter 1. "Product Overview"** – Important information about the MCP73833 Li-Ion Battery Charger Evaluation Board.
- **Chapter 2. "Installation and Operation"** – Includes instructions on how to get started with this evaluation kit and a description of the evaluation boards.
- **Appendix A. "Schematic and Layouts"** – Shows the schematic and layout diagrams for the MCP73833 Li-Ion Battery Charger Evaluation Board.
- **Appendix B. "Bill Of Materials (BOM)"** – Lists the parts used to build the MCP73833 Li-Ion Battery Charger Evaluation Board.

MCP73833 Li-Ion Battery Charger Evaluation Board User's Guide

CONVENTIONS USED IN THIS GUIDE

This manual uses the following documentation conventions:

DOCUMENTATION CONVENTIONS

Description	Represents	Examples
Arial font:		
Italic characters	Referenced books	<i>MPLAB[®] IDE User's Guide</i>
	Emphasized text	...is the <i>only</i> compiler...
Initial caps	A window	the Output window
	A dialog	the Settings dialog
	A menu selection	select Enable Programmer
Quotes	A field name in a window or dialog	"Save project before build"
Underlined, italic text with right angle bracket	A menu path	<u><i>File>Save</i></u>
Bold characters	A dialog button	Click OK
	A tab	Click the Power tab
N'Rnnnn	A number in verilog format, where N is the total number of digits, R is the radix and n is a digit.	4'b0010, 2'hF1
Text in angle brackets < >	A key on the keyboard	Press <Enter>, <F1>
Courier New font:		
Plain Courier New	Sample source code	#define START
	Filenames	autoexec.bat
	File paths	c:\mcc18\h
	Keywords	_asm, _endasm, static
	Command-line options	-Opa+, -Opa-
	Bit values	0, 1
	Constants	0xFF, 'A'
Italic Courier New	A variable argument	<i>file.o</i> , where <i>file</i> can be any valid filename
Square brackets []	Optional arguments	mcc18 [options] <i>file</i> [options]
Curly brackets and pipe character: { }	Choice of mutually exclusive arguments; an OR selection	errorlevel {0 1}
Ellipses...	Replaces repeated text	var_name [, var_name...]
	Represents code supplied by user	void main (void) { ... }

RECOMMENDED READING

This user's guide describes how to use MCP73833 Li-Ion Battery Charger Evaluation Board. Other useful documents are listed below. The following Microchip documents are available and recommended as supplemental reference resources.

MCP73833 Data Sheet, “Stand-Alone Linear Li-Ion / Li-Polymer Charge Management Controller” (DS22005)

This data sheet provides detailed information regarding the MCP73831 product family.

AN947, “Power Management in Portable Applications: Charging Lithium-Ion / Lithium-Polymer Batteries” (DS00947)

This application note provides general information regarding charging Li-Ion batteries.

AN971, “USB Port-Powered Li-Ion/Li-Polymer Battery Charging” (DS00971)

This application note provides general information regarding charging Li-Ion batteries from a USB port.

THE MICROCHIP WEB SITE

Microchip provides online support via our web site at www.microchip.com. This web site is used as a means to make files and information easily available to customers. Accessible by using your favorite Internet browser, the web site contains the following information:

- **Product Support** – Data sheets and errata, application notes and sample programs, design resources, user's guides and hardware support documents, latest software releases and archived software
- **General Technical Support** – Frequently Asked Questions (FAQs), technical support requests, online discussion groups, Microchip consultant program member listing
- **Business of Microchip** – Product selector and ordering guides, latest Microchip press releases, listing of seminars and events, listings of Microchip sales offices, distributors and factory representatives

CUSTOMER SUPPORT

Users of Microchip products can receive assistance through several channels:

- Distributor or Representative
- Local Sales Office
- Field Application Engineer (FAE)
- Technical Support
- Development Systems Information Line

Customers should contact their distributor, representative or field application engineer (FAE) for support. Local sales offices are also available to help customers. A listing of sales offices and locations is included in the back of this document.

Technical support is available through the web site at: <http://support.microchip.com>

DOCUMENT REVISION HISTORY

Revision A (September 2006)

- Initial Release of this Document.

MCP73833 Li-Ion Battery Charger Evaluation Board User's Guide

NOTES:

Chapter 1. Product Overview

1.1 INTRODUCTION

The MCP73833 Li-Ion Battery Charger Evaluation Board is used to evaluate Microchip Technology's MCP73833/4 in simple, stand-alone Li-Ion battery charging applications. Two circuit layouts are provided for evaluation of various device options in either the DFN or MSOP package.

This chapter covers the following topics:

- What is the MCP73833 Li-Ion Battery Charger Evaluation Board?
- What the MCP73833 Evaluation Kit Includes

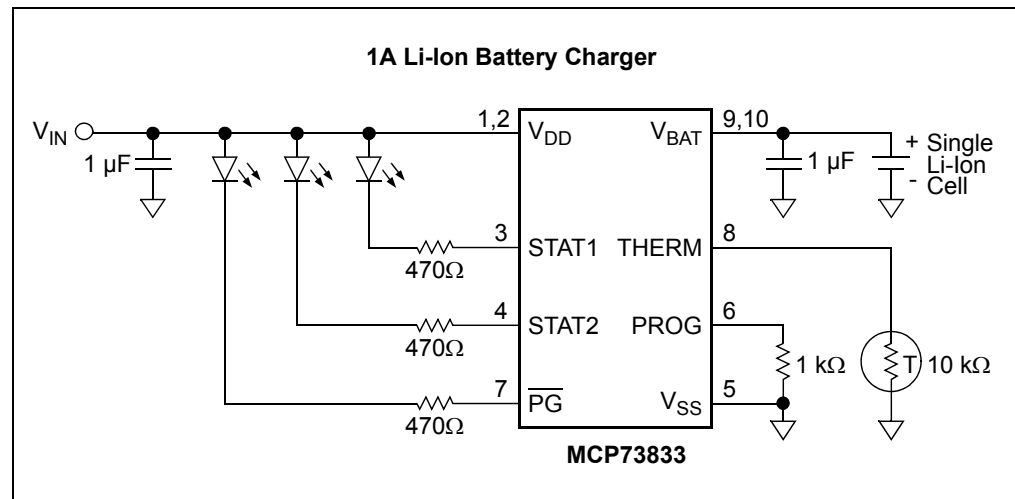

FIGURE 1-1: Typical MCP73833 Application.

1.2 WHAT IS THE MCP73833 LI-ION BATTERY CHARGER EVALUATION BOARD?

The MCP73833 Li-Ion Battery Charger Evaluation Board is an evaluation and demonstration tool for Microchip's MCP73833/4 Stand-Alone Linear Li-Ion/Li-Polymer Charge Management Controllers.

The evaluation board has two circuits provided with one circuit fully assembled and tested. Each circuit is set up to evaluate simple, stand-alone, linear charging of single cell Li-Ion / Li-Polymer battery packs (the battery packs are not included). The circuits can be evaluated independently. Each circuit design provides constant current charging followed by constant voltage charging with automatic charge termination and battery temperature monitoring. In addition, the assembled MCP73833/4-FC circuit provides preconditioning of deeply depleted cells.

Each board design provides evaluation of the MCP73833/4 in two package options: a MSOP-10 (not assembled) and a 3mm x 3mm, 10-Lead DFN (assembled) for higher power handling capability.

When connected, this evaluation board allows for the evaluation of the MCP73833/4 devices in a variety of applications.

1.3 WHAT THE MCP73833 EVALUATION KIT INCLUDES

This MCP73833 Li-Ion Battery Charger Evaluation Board Kit includes:

- MCP73833 Li-Ion Battery Charger Evaluation Board, 102-00117
- Analog and Interface Products Demonstration Boards CD-ROM, (DS21912)
 - MCP73833 Li-Ion Battery Charger Evaluation Board User's Guide, (DS51526)



MCP73833 LI-ION BATTERY CHARGER EVALUATION BOARD USER'S GUIDE

Chapter 2. Installation and Operation

2.1 INTRODUCTION

The MCP73833 Li-Ion Battery Charger Evaluation Board demonstrates Microchip Technology's MCP73833/4 devices. The MCP73833/4 is a Stand-Alone Linear Li-Ion/Li-Polymer Charge Management Controller. A number of device options allow the MCP73833/4 to be utilized in a variety of applications. Refer to the MCP73833/4 data sheet (DS22005) for device options.

2.2 FEATURES

The MCP73833 Li-Ion Battery Charger Evaluation Board contains two evaluation circuits for evaluation of various device options. The board has the following features with the factory installed device (MCP73833-FCI/MF):

- Charge Voltage: 4.20V
- Programmable Fast Charge Current up to 1000 mA
- Preconditioning of deeply depleted cells
 - Preconditioning Threshold Voltage: 3.0V
 - Preconditioning Current: 10% of Programmed Fast Charge Current
- Automatic Charge Termination
 - Charge termination by minimum current in Constant Voltage Mode
 - Charge termination by safety time period: 6 hours
 - Termination Current: 7.5% of Programmed Fast Charge Current
- Automatic Recharge
 - Recharge Threshold Voltage: 4.05V
- Cell Temperature Monitoring
- Charge Current Monitor for Fuel Guaging
- Thermal Regulation
- Reverse Discharge Protection
- Evaluation in 3mm x 3mm, 10-Lead DFN Package for higher power handling capability
- Simple Stand-Alone Operation
- Powered from external bench supply or voltage regulated wall cube
- Surface-Mount Design
- One Circuit Fully Assembled and Tested

MCP73833 Li-Ion Battery Charger Evaluation Board User's Guide

2.3 GETTING STARTED

The MCP73833 Li-Ion Battery Charger Evaluation Board has one circuit fully assembled and tested for charging single cell, Li-Ion/Li-Polymer battery packs. The board provides the appropriate charge algorithm for simple, stand-alone operation.

The board requires the use of an external input voltage source ($5V \pm 10\%$, recommended) and external load (battery pack or simulated battery load).

2.3.1 Power Input and Output Connections

2.3.1.1 POWERING THE MCP73833 LI-ION BATTERY CHARGER EVALUATION BOARD

1. Apply the input voltage source to the appropriate circuit for evaluation. The input voltage source should be limited to the 0V to +6V range. For normal operation, the input voltage should be between +4.5V and +6V. The input voltage must not exceed an absolute maximum of +7V.
2. Connect the positive side of the input source (+) to VDD of the circuit being evaluated. Connect the negative or return side of the input source (-) to VSS of the circuit being evaluated. Refer to [Figure 2-1](#).

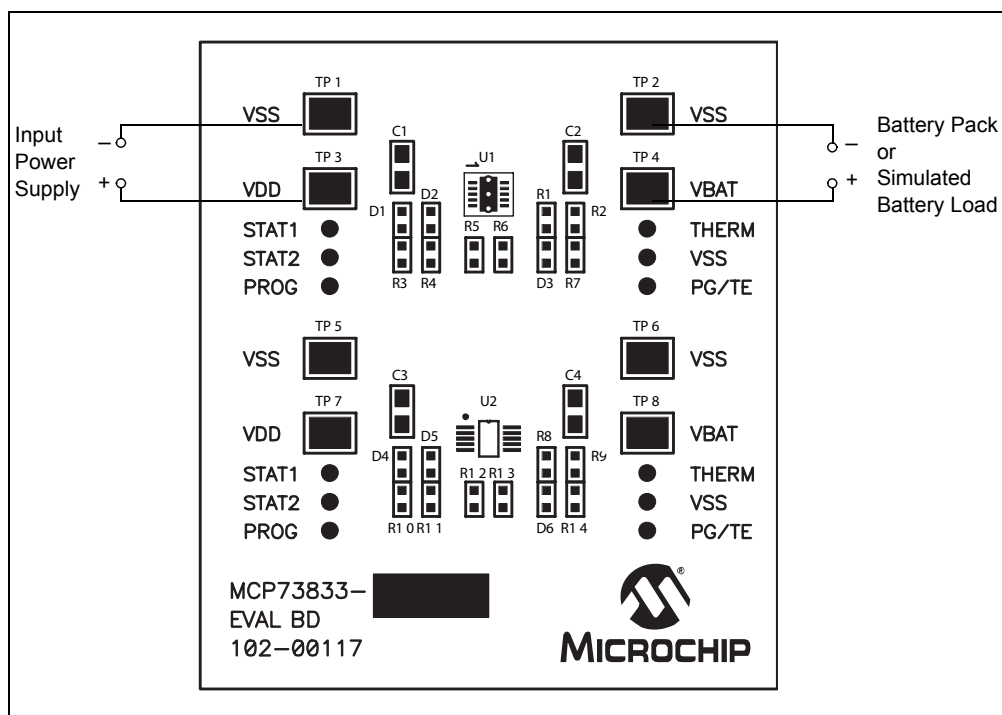

FIGURE 2-1: Setup Configuration Diagram.

2.3.1.2 APPLYING THE LOAD TO THE MCP73833 LI-ION BATTERY CHARGER EVALUATION BOARD

1. To apply a load to the MCP73833 Li-Ion Battery Charger Evaluation Board, the positive side of the load (B+) should be connected to VBAT of the circuit being evaluated. The negative or return side of the load (B-) should be connected to VSS of the circuit being evaluated. Care should be taken when using electronic loads or ground referenced loads.
2. For the MCP73833-FCI/MF installed device, the charge management controller will only provide 10% of the programmed fast charge current if the battery terminal voltage (VBAT) is less than 3.0V with respect to VSS. Using a purely resistive

Installation and Operation

load will not work for preconditioning and fast charge currents. The best way to evaluate the charge management circuit is to use a single cell Li-Ion battery pack, or the recommended simulated battery load. Refer to [Figure 2-2](#).

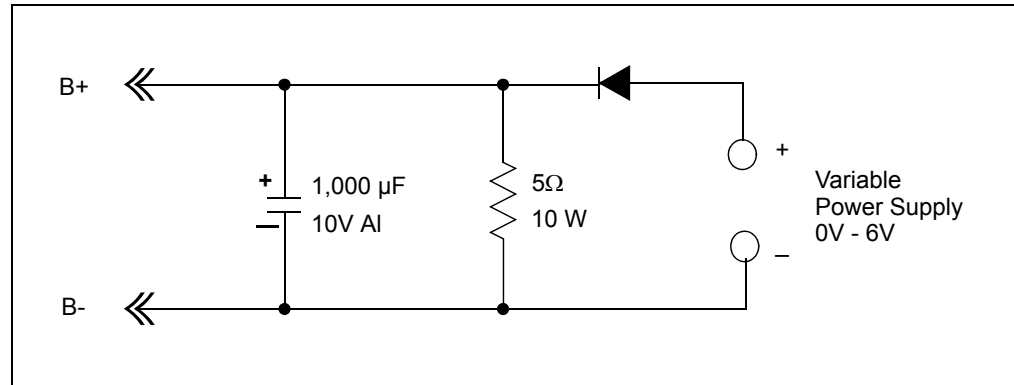

FIGURE 2-2: Simulated Battery Load.

2.3.1.3 SETTING THE FAST CHARGE CURRENT

1. As provided, the MCP73833 Li-Ion Battery Charger Evaluation Board has a fast charge current setting of 1A for the installed device.
2. Alternatively, for the installed device, resistors R5 and R6 can be changed in order to obtain the desired fast charge current. In addition, the PROG via can be interfaced to obtain two current settings or to utilize the PROG device enable feature. Refer to the MCP73833/4 data sheet for choosing the appropriate value programming resistor for the desired fast charge current.

2.3.1.4 STATUS INDICATORS

1. The MCP73833 Li-Ion Battery Charger Evaluation Board has three LED status indicators for each circuit being evaluated. [Table 2-1](#) represents the state of the status indicators during various states of the charge cycle. ON indicates that the respective LED is illuminated.

TABLE 2-1: STATUS INDICATORS

CHARGE CYCLE STATE	STAT1 (RED)	STAT2 (GREEN)	PG (GREEN)
Shutdown	OFF	OFF	OFF
Standby	OFF	OFF	ON
Charge in Progress	ON	OFF	ON
Charge Complete (EOC)	OFF	ON	ON
Temperature Fault	OFF	OFF	ON
Timer Fault	OFF	OFF	ON
System Test Mode	ON	ON	ON

2.3.1.5 BATTERY TEMPERATURE MONITOR

1. As provided, the installed circuit of the MCP73833 Li-Ion Battery Charger Evaluation Board has the battery temperature monitor disabled. To invoke battery temperature monitoring, an appropriate thermistor should be connected between the THERM via and VSS via. In addition, resistors R2 and R7 should be changed in order to obtain the desired charge inhibit window. Refer to the MCP73833/4 data sheet for choosing the appropriate resistor values. charge current monitor for each circuit being evaluated.

2.3.1.6 DEVICE SUPPORT OPTIONS

1. The MCP73833 Li-Ion Battery Charger Evaluation Board is capable of supporting all of the available MCP73833/4 device options. The factory installed device is the MCP73833-FCI/MF. Refer to the MCP73833/4 data sheet for available device options and details regarding the installed device options.



MCP73833 LI-ION BATTERY CHARGER EVALUATION BOARD USER'S GUIDE

Appendix A. Schematic and Layouts

A.1 INTRODUCTION

This appendix contains the following schematic and layouts for the MCP73833 Li-Ion Battery Charger Evaluation Board.

Diagrams included in this appendix:

- Board Schematic
- Board - Top Overlay
- Board - Top Layer
- Board - Bottom Layer

MCP73833 Li-Ion Battery Charger Evaluation Board User's Guide

A.2 BOARD SCHEMATIC

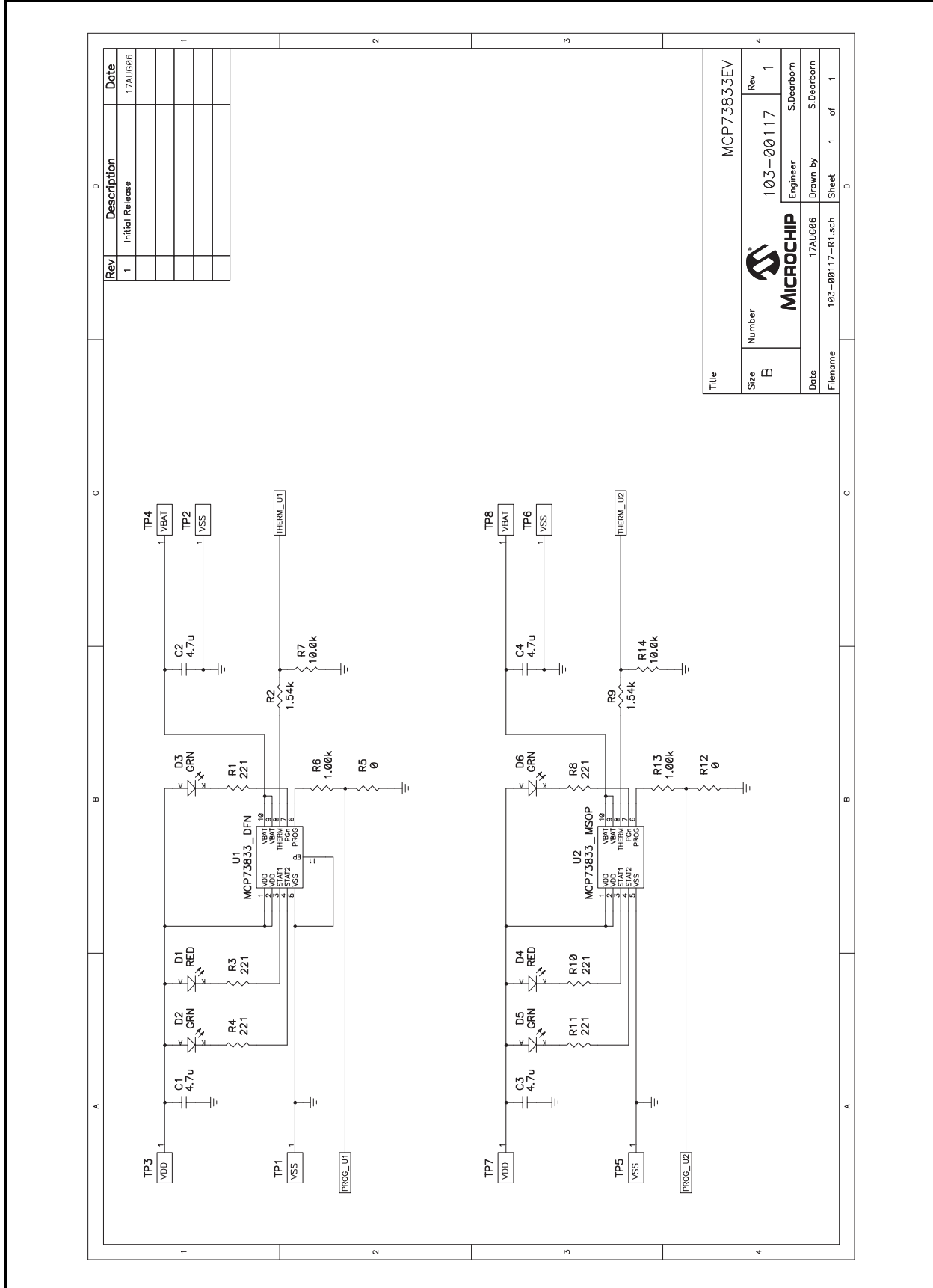

Rev	Description	Date
1	Initial Release	17AUG06

Title		MCP73833EV	
Size	Number	Rev	
B	103-00117	1	
Date	Engineer	Drawn by	
17AUG06	S. Dearborn	S. Dearborn	
Filename	103-00117-R1.sch	Sheet	1 of 1

A.3 BOARD - TOP OVERLAY

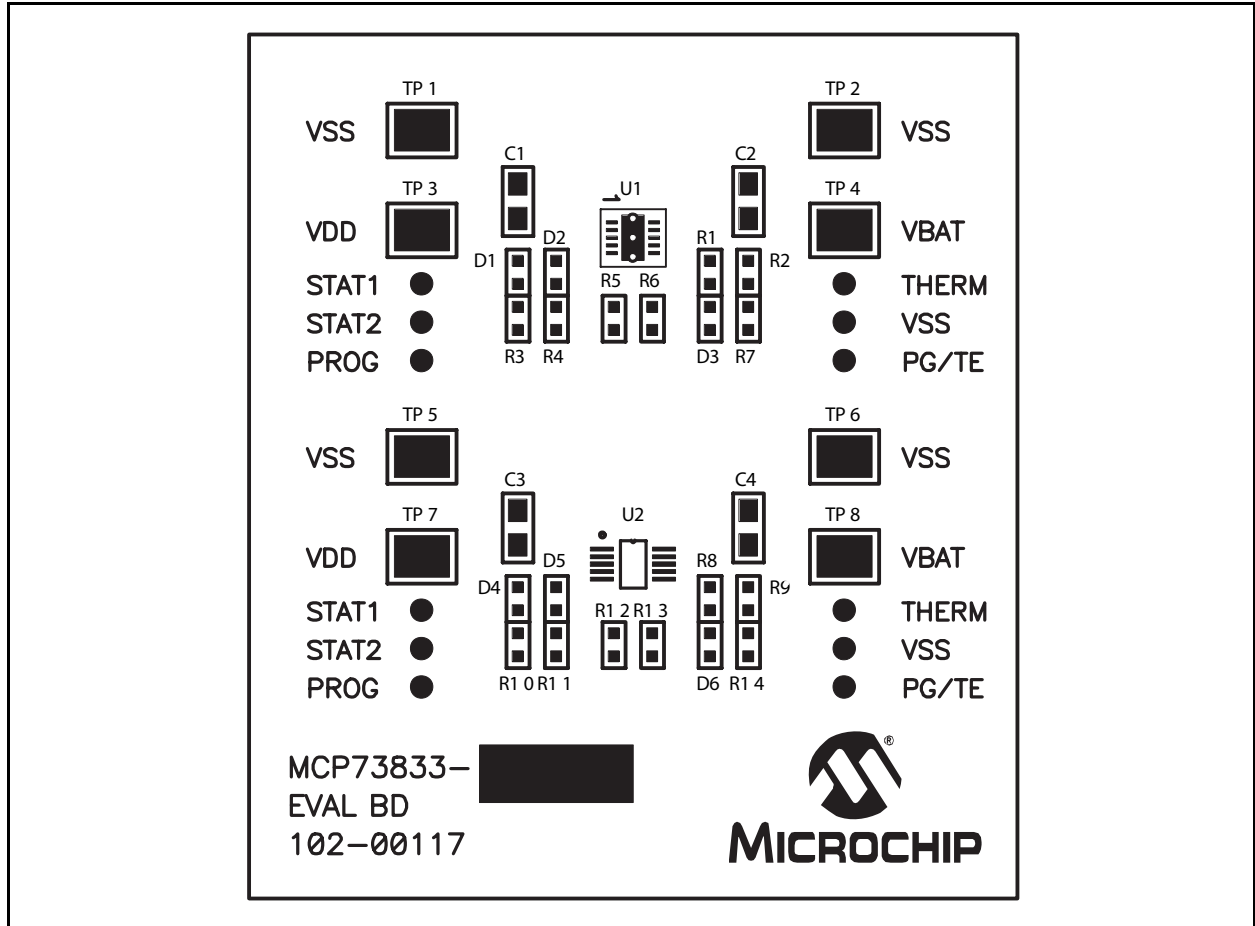

A.4 BOARD - TOP LAYER

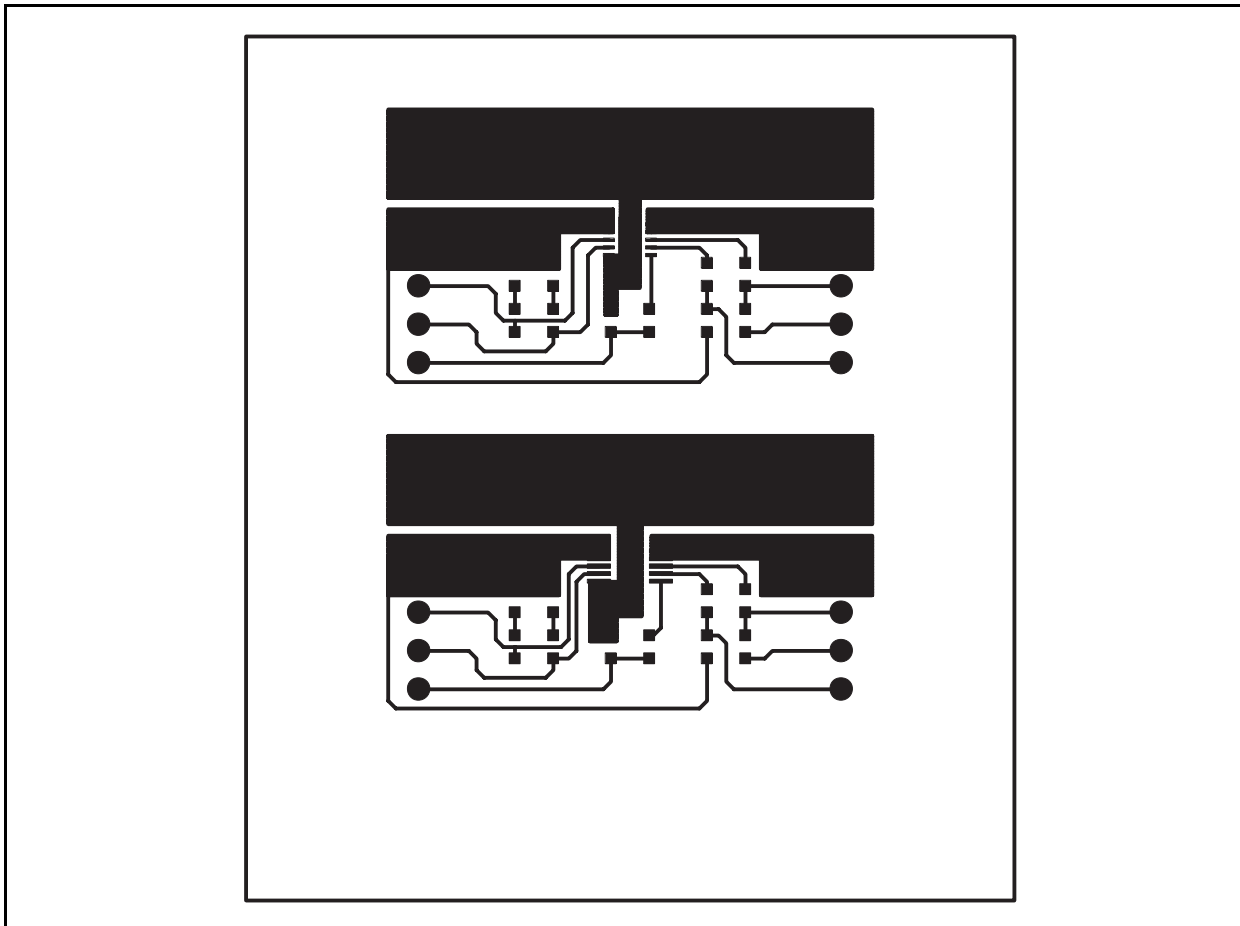

A.5 BOARD - BOTTOM LAYER

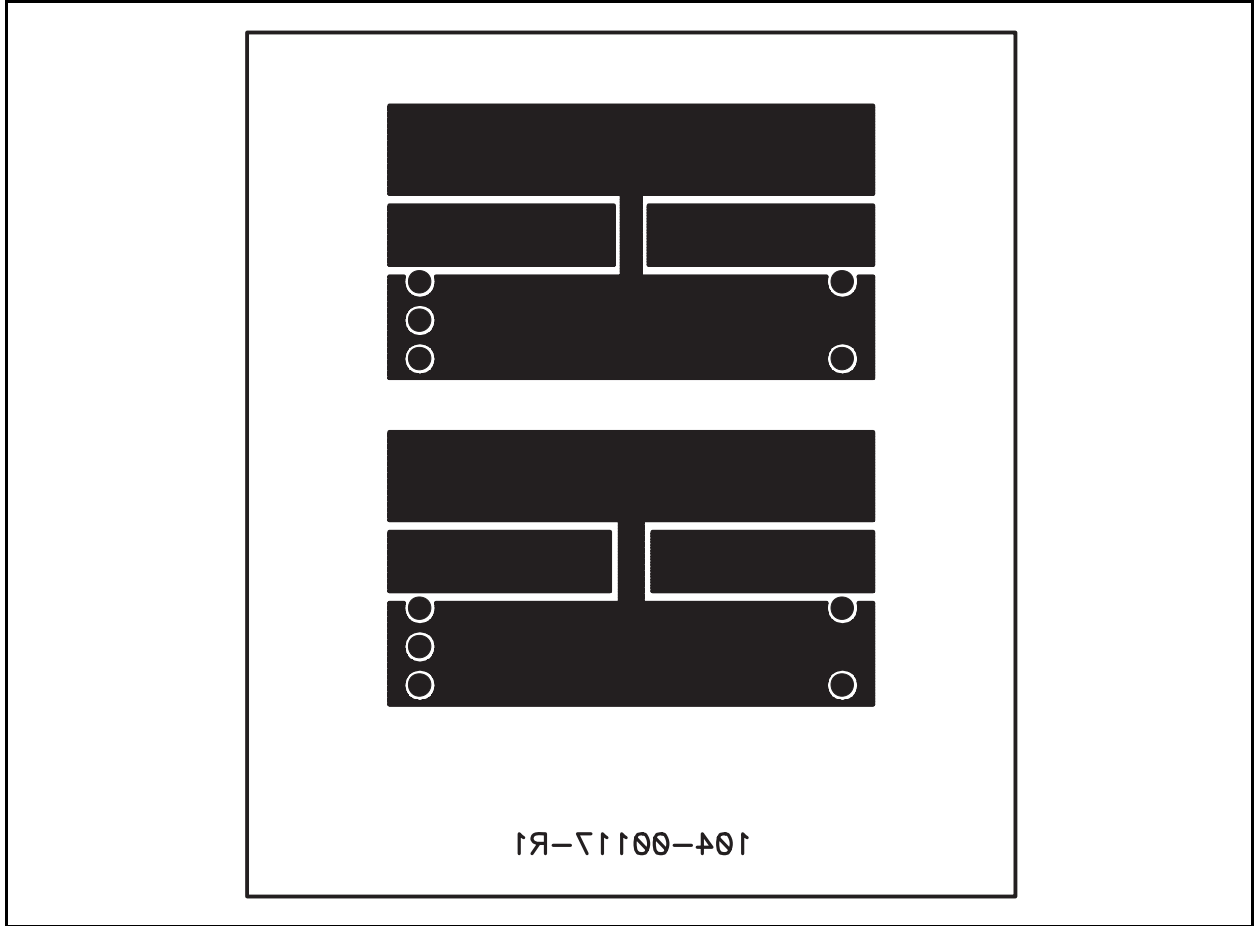

MCP73833 Li-Ion Battery Charger Evaluation Board User's Guide

NOTES:



MCP73833 LI-ION BATTERY CHARGER EVALUATION BOARD USER'S GUIDE

Appendix B. Bill Of Materials (BOM)

TABLE B-1: BILL OF MATERIALS (BOM)

Qty.	Reference	Description	Mfgr.	Part Number
2	C1,C2	4.7uF, X7R Ceramic, 10V, 0805	Taiyo Yuden [®]	LMK212BJ475KG-TR
1	D1	Super Red LED, 0603	Lumex [®]	LTST-C190KRKT
2	D2,D3	Green LED, 0603	Lumex	LTST-C190KGKT
3	R1,R3,R4	221, 1/10W, Chip Resistor, 0603	Panasonic [®] -ECG	ERJ-3EKF2210V
1	R2	1.54k, 1/10W, Chip Resistor, 0603	Panasonic-ECG	ERJ-3EKF1541V
1	R5	0, 1/10W, Chip Resistor, 0603	Panasonic-ECG	ERJ-3GEY0R00V
1	R6	1.00k, 1/10W, Chip Resistor, 0603	Panasonic-ECG	ERJ-3EKF1001V
1	R7	10.0k, 1/10W, Chip Resistor, 0603	Panasonic-ECG	ERJ-3EKF1002V
4	TP1-TP4	Surface Mount Test Point, 5016	Keystone Electronics [®]	5016
1	U1	1A Fully Integrated Charger, 3X3DFN10	Microchip Technology Inc.	MCP73833-FCI/MF
4		Bump-ons	3M [™]	SJ5003
1		Printed Circuit Board	Advanced Circuits	104-00117-R1

Note 1: The components listed in this Bill of Materials are representative of the PCB assembly. The released BOM used in manufacturing uses all RoHS-compliant components.



MICROCHIP

WORLDWIDE SALES AND SERVICE

AMERICAS

Corporate Office

2355 West Chandler Blvd.
Chandler, AZ 85224-6199
Tel: 480-792-7200
Fax: 480-792-7277
Technical Support:
<http://support.microchip.com>
Web Address:
www.microchip.com

Atlanta

Alpharetta, GA
Tel: 770-640-0034
Fax: 770-640-0307

Boston

Westborough, MA
Tel: 774-760-0087
Fax: 774-760-0088

Chicago

Itasca, IL
Tel: 630-285-0071
Fax: 630-285-0075

Dallas

Addison, TX
Tel: 972-818-7423
Fax: 972-818-2924

Detroit

Farmington Hills, MI
Tel: 248-538-2250
Fax: 248-538-2260

Kokomo

Kokomo, IN
Tel: 765-864-8360
Fax: 765-864-8387

Los Angeles

Mission Viejo, CA
Tel: 949-462-9523
Fax: 949-462-9608

Santa Clara

Santa Clara, CA
Tel: 408-961-6444
Fax: 408-961-6445

Toronto

Mississauga, Ontario,
Canada
Tel: 905-673-0699
Fax: 905-673-6509

ASIA/PACIFIC

Asia Pacific Office

Suites 3707-14, 37th Floor
Tower 6, The Gateway
Harbour City, Kowloon
Hong Kong
Tel: 852-2401-1200
Fax: 852-2401-3431

Australia - Sydney

Tel: 61-2-9868-6733
Fax: 61-2-9868-6755

China - Beijing

Tel: 86-10-8528-2100
Fax: 86-10-8528-2104

China - Chengdu

Tel: 86-28-8665-5511
Fax: 86-28-8665-7889

China - Fuzhou

Tel: 86-591-8750-3506
Fax: 86-591-8750-3521

China - Hong Kong SAR

Tel: 852-2401-1200
Fax: 852-2401-3431

China - Qingdao

Tel: 86-532-8502-7355
Fax: 86-532-8502-7205

China - Shanghai

Tel: 86-21-5407-5533
Fax: 86-21-5407-5066

China - Shenyang

Tel: 86-24-2334-2829
Fax: 86-24-2334-2393

China - Shenzhen

Tel: 86-755-8203-2660
Fax: 86-755-8203-1760

China - Shunde

Tel: 86-757-2839-5507
Fax: 86-757-2839-5571

China - Wuhan

Tel: 86-27-5980-5300
Fax: 86-27-5980-5118

China - Xian

Tel: 86-29-8833-7250
Fax: 86-29-8833-7256

ASIA/PACIFIC

India - Bangalore

Tel: 91-80-4182-8400
Fax: 91-80-4182-8422

India - New Delhi

Tel: 91-11-4160-8631
Fax: 91-11-4160-8632

India - Pune

Tel: 91-20-2566-1512
Fax: 91-20-2566-1513

Japan - Yokohama

Tel: 81-45-471-6166
Fax: 81-45-471-6122

Korea - Gumi

Tel: 82-54-473-4301
Fax: 82-54-473-4302

Korea - Seoul

Tel: 82-2-554-7200
Fax: 82-2-558-5932 or
82-2-558-5934

Malaysia - Penang

Tel: 60-4-646-8870
Fax: 60-4-646-5086

Philippines - Manila

Tel: 63-2-634-9065
Fax: 63-2-634-9069

Singapore

Tel: 65-6334-8870
Fax: 65-6334-8850

Taiwan - Hsin Chu

Tel: 886-3-572-9526
Fax: 886-3-572-6459

Taiwan - Kaohsiung

Tel: 886-7-536-4818
Fax: 886-7-536-4803

Taiwan - Taipei

Tel: 886-2-2500-6610
Fax: 886-2-2508-0102

Thailand - Bangkok

Tel: 66-2-694-1351
Fax: 66-2-694-1350

EUROPE

Austria - Wels

Tel: 43-7242-2244-3910
Fax: 43-7242-2244-393

Denmark - Copenhagen

Tel: 45-4450-2828
Fax: 45-4485-2829

France - Paris

Tel: 33-1-69-53-63-20
Fax: 33-1-69-30-90-79

Germany - Munich

Tel: 49-89-627-144-0
Fax: 49-89-627-144-44

Italy - Milan

Tel: 39-0331-742611
Fax: 39-0331-466781

Netherlands - Drunen

Tel: 31-416-690399
Fax: 31-416-690340

Spain - Madrid

Tel: 34-91-708-08-90
Fax: 34-91-708-08-91

UK - Wokingham

Tel: 44-118-921-5869
Fax: 44-118-921-5820

08/29/06